

Conference and Meetings

Whatever the occasion we are here to help you and we thank you for considering the BEST WESTERN PLUS Angel Hotel as a venue.

You may already know exactly how you envisage your event, if so tell us and we will arrange it for you. However, if you don't know where to begin, don't worry with our years of experience; we will guide you through the decisions.



If you have not visited the hotel recently it will be well worth your while seeing the facilities on offer to all of our guests. As well as the Avon Suite (which is fully air conditioned) with a private bar just across the corridor, the newly refurbished ground floor area of the hotel offers a Brasserie and a stylish lounge and bar. We can cater for up to 100 delegates in the Avon Suite for a theatre style meeting.

Overnight accommodation if required is to be found in both the courtyard wing and the main building all of which has undergone substantial refurbishment in recent years.

Day delegate £31.50 per person

Inclusive of:

- Room hire,
- Unlimited tea and coffee
- Buffet lunch number 1
- Iced water, sweets, cordials, paper, pencils
- Fruit bowl
- LCD projector and screen
- Flipchart
- FREE WIFI in room

24 Hour rate £162.50 per person

Inclusive of:

- A full day delegate package PLUS
- 1 night's accommodation
- 3 course dinner
- Full English breakfast



Room hire rates

	Full Day	Half Day
Avon Suite	£400	£260
Allington	£190	£115
Monkton	£190	£115
Bowood	£150	£100
Syndicate room	£90	£50

Equipment and services

Flipchart, paper and pens £10.00

LCD projector and screen £50.00

TV and Video / DVD £35.00

OHP and screen £20.00

All other items available on request



Finger buffet menus

Buffet 1 ~ £12.55

Selection of sandwiches
 Cocktail sausages in honey and mustard
 Lemongrass and ginger chicken skewers
 Duo of home-made vegetarian quiche
 Grilled vegetable skewers
 Salmon goujons
 Selection of individual desserts
 Bowl of whole fresh fruit

Buffet 2 ~ £14.10

Selection of sandwiches and baquettes
 Oriental chicken wings
 Mini cheese burgers
 Duo of home-made vegetarian quiche
 Grilled vegetable skewers
 Individual mini sausage rolls
 Salmon bites
 Selection of individual desserts
 Bowl of whole fresh fruit

Buffet 3 ~ £16.20

Selection of sandwiches, baguettes and wraps
 Grilled vegetable skewers
 Salmon goujons
 Salmon and spinach roulade
 Chicken drumsticks
 Cocktail sausages with a BBQ glaze
 Selection of mixed crustini
 Duo of home-made vegetarian quiche
 Chicken skewers
 Selection of individual desserts
 Bowl of whole fresh fruit



ADDITIONAL ITEMS:

To enhance your meeting why not add one or more of the following to any standard package. All prices are per person unless otherwise stated

Orange juice: £5.15 per jug
 Bottled mineral water £3.75 per bottle
 Additional tea, coffee and biscuits: £2.25
 Selection of bacon & omelette rolls: £2.70
 Selection of mini Danish pastries: £1.60
 Scones with jam and cream: £1.60

Room plans and Capacities

Bowood suite

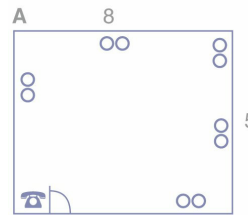

Avon Suite

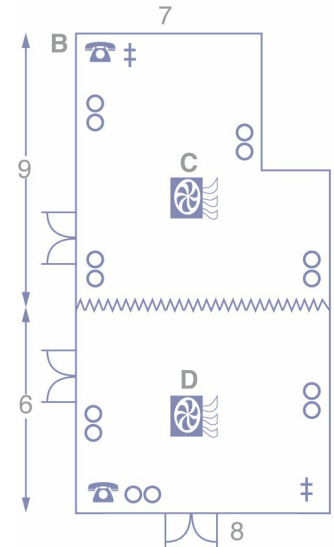

Key

= 13 amp socket	= Door
= Telephone point	= Aerial
= Folding partition	= Air Conditioning

Room information

		Bowood (A)	Avon (B)	Monkton (C)	Allington (D)
Room Sizes	Length	8	15	9	8
	Width	5	7	7	6
	Height	3	3	3	3
Maximum Numbers	Theatre	30	100	60	50
	Classroom	12	50	24	24
	Boardroom	14	50	26	30
	U Shape	12	40	18	25
	Banquet	N/A	100	48	50
Info	Daylight	Yes	Yes	Yes	No
	Location	First	Grd	Grd	Grd
	Blackout	Yes	Yes	Yes	Yes

For further information or to place a booking please call or email:-

www.angelhotelchippenham.co.uk
 01249 652615